

SW TYPE (Inch Standard)

– Standard Type –



part number structure

example **SWS16GRUU-P**

specification SW : standard SWS : anti-corrosion	size	retainer material blank : standard/steel anti-corrosion/stainless steel G : resin	accuracy grade blank : high P : precision	seal blank : without seal U : seal on one side UU : seals on both sides	self aligning blank : non self aligning R : self aligning *
--	------	--	---	---	---

*Seals are not available on SWS2 and SWS3.

*Self-aligning is available only with resin retainer for size 4 to 32 of carbon steel cylinder.

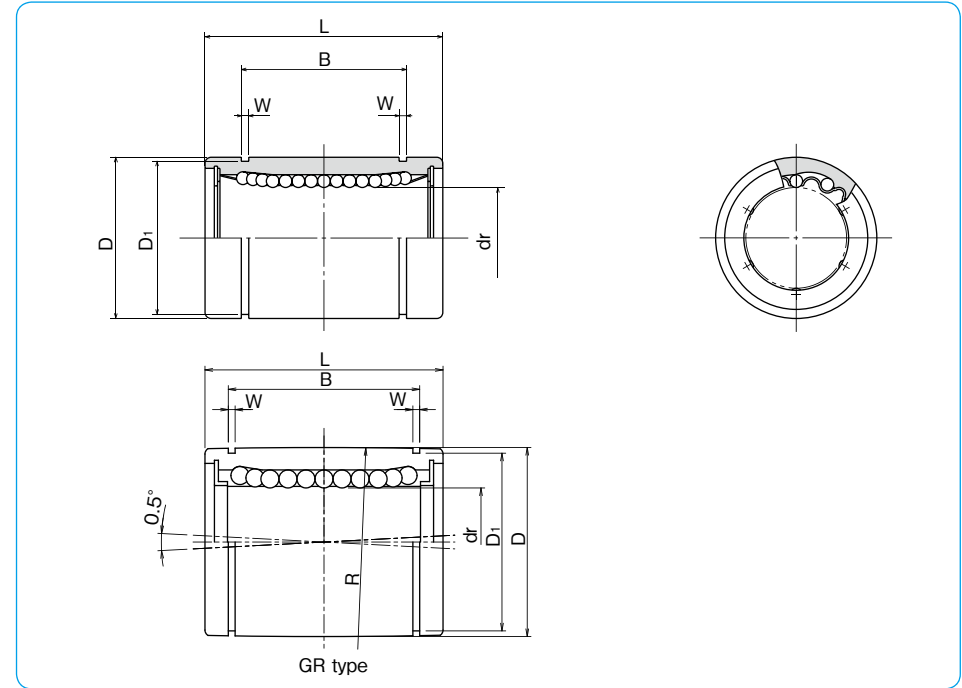

partnumber		major dimensions		number of ball circuits	dr		D		
steel retainer	standard resinretainer	anti-corrosion stainless retainer	anti-corrosion resin retainer		inch (mm)	tolerance precision	inch/(μm) high	inch (mm)	tolerance inch/(μm)
-	-	-	SWS2	SWS2G	4	.1250 (3.175)	0	.3125 (7.938)	0
-	-	-	SWS3	SWS3G	4	.1875 (4.763)	-0.00035 (-8)	.3750 (9.525)	-0.00040 (-9)
SW4	SW4G	SW4GR	SWS4	SWS4G	4	.2500 (6.350)	0	.5000 (12.700)	-0.00045 (-11)
SW6	SW6G	SW6GR	SWS6	SWS6G	4	.3750 (9.525)	-0.00025 (-6)	.6250 (15.875)	0
SW8	SW8G	SW8GR	SWS8	SWS8G	4	.5000 (12.700)	-0.00040 (-9)	.8750 (22.225)	-0.00050 (-13)
SW10	SW10G	SW10GR	SWS10	SWS10G	4	.625 (15.875)	0	1.1250 (28.575)	0
SW12	SW12G	SW12GR	SWS12	SWS12G	5	.7500 (19.050)	-0.00030 (-7)	1.2500 (31.750)	-0.00065 (-16)
SW16	SW16G	SW16GR	SWS16	SWS16G	6	1.0000 (25.400)	0	1.5625 (39.688)	0
SW20	SW20G	SW20GR	SWS20	SWS20G	6	1.2500 (31.750)	0	2.0000 (50.800)	-0.00075 (-19)
SW24	SW24G	SW24GR	SWS24	SWS24G	6	1.5000 (38.100)	-0.00035 (-8)	2.3750 (60.325)	0
SW32	SW32G	SW32GR	SWS32	SWS32G	6	2.0000 (50.800)	0	3.0000 (76.200)	-0.00090 (-22)
SW40	-	-	-	-	6	2.5000 (63.500)	-0.00040 (-9)	3.7500 (95.250)	0
SW48	-	-	-	-	6	3.0000 (76.200)	-0.00060 (-15)	4.5000 (114.300)	0
SW64	-	-	-	-	6	4.0000 (101.600)	-0.00040 (-10)	6.0000 (152.400)	-0.00100 (-25)

L		B		W	D ₁	eccentricity		radial clearance	basic load rating	dynamic	static	mass	shaft diameter
inch (mm)	tolerance inch/(mm)	inch (mm)	tolerance inch/(mm)	inch (mm)	inch (mm)	precision inch/(μm)	high inch/(μm)	(maximum) inch/(μm)	C N	Co N	g	inch (mm)	
5000 (12.700)		.3681 (9.35)		.0280 (0.710)	.2902 (7.370)	-	.0003 (8)	-.0001 (-2)	59	76	2.8	1/8 (3.175)	
.5625 (14.275)		.4311 (10.95)		.0280 (0.710)	.3520 (8.940)				91	110	3.6	3/16 (4.763)	
.7500 (19.050)	0	.5110 (12.98)	0	.0390 (0.992)	.4687 (11.906)			-.0001 (-3)	206	265	9.5	1/4 (6.350)	
.8750 (22.225)	-0.008 (-0.2)	.6358 (16.15)	-0.008 (-0.2)	.0390 (0.992)	.5880 (14.935)	.0003 (8)	.0005 (12)		225	314	15	3/8 (9.525)	
1.2500 (31.750)		.9625 (24.46)		.0459 (1.168)	.8209 (20.853)			-.0001 (-4)	510	784	42	1/2 (12.700)	
1.5000 (38.100)		1.1039 (28.575)		.0559 (1.422)	1.0590 (26.899)				774	1,180	85	5/8 (15.875)	
1.6250 (41.275)		1.1657 (29.61)		.0559 (1.422)	1.1760 (29.870)	.0004 (10)	.0006 (15)	-.0002 (-6)	862	1,370	104	3/4 (19.050)	
2.2500 (57.150)		1.7547 (44.57)		.0679 (1.727)	1.4687 (37.306)				980	1,570	220	1 (25.400)	
2.6250 (66.675)	0	2.0047 (50.92)	0	.0679 (1.727)	1.8859 (47.904)	.0005 (12)	.0008 (20)	-.0003 (-8)	1,570	2,740	465	1-1/4 (31.750)	
3.0000 (76.200)	-0.012 (-0.3)	2.4118 (61.26)	-0.012 (-0.3)	.0859 (2.184)	2.2389 (56.870)				2,180	4,020	720	1-1/2 (38.100)	
4.0000 (101.600)		3.1917 (81.07)		.1029 (2.616)	2.8379 (72.085)			-.0005 (-13)	3,820	7,940	1,310	2 (50.800)	
5.0000 (127.000)		3.9760 (100.99)		.1200 (3.048)	3.5519 (90.220)	.0007 (17)	.0010 (25)		4,700	10,000	2,600	2-1/2 (63.500)	
6.0000 (152.400)	0	4.726 (120.04)	0	.1200 (3.048)	4.3100 (109.474)			-.0008 (-20)	7,350	16,000	4,380	3 (76.200)	
8.0000 (203.200)	-0.016 (-0.4)	6.258 (158.95)	-0.016 (-0.4)	.1389 (3.530)	5.745 (145.923)	.0008 (20)	.0012 (30)		14,100	34,800	10,200	4 (101.600)	

1N≐0.225lbf 1kg≐2.205lbf